

# 1. Foundation Details

## 1.1 Insulated Slab Edge

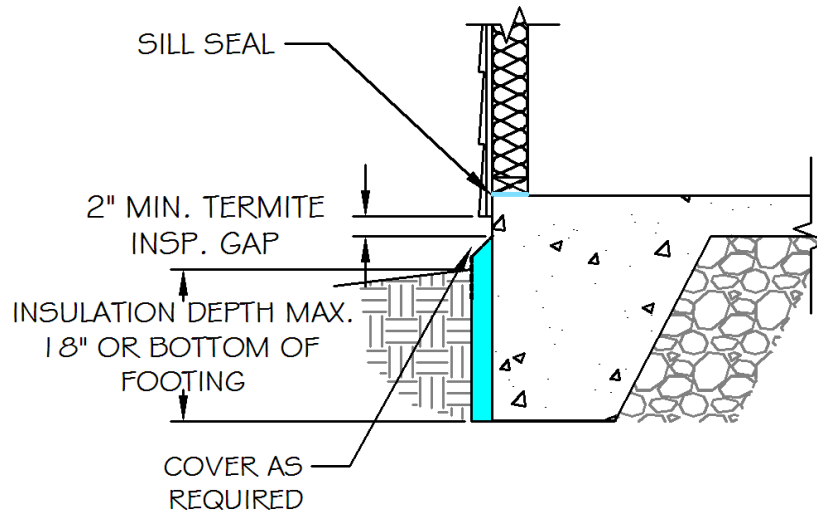

*DISCLAIMER: This material was prepared by North Carolina Energy Efficiency Alliance, a nonprofit organization. Neither the NCEEA, its member organizations, the acknowledged individuals, nor any person acting on behalf of them: (a) makes any warranty, express or implied, with respect to the use of any information, apparatus, method or process disclosed in this publication that such use may not infringe privately owned rights; or (b) assumes any liability with respect to the use of, or for direct or consequential damages resulting from the use of, any information, apparatus, method or process disclosed in this publication; or (c) has any liability for damages that result from any negligent act or omission involved in the preparation of the material. Any implied warranty of merchantability or fitness for a particular use is specifically excluded.*

## 1.2 Sealed Crawlspace

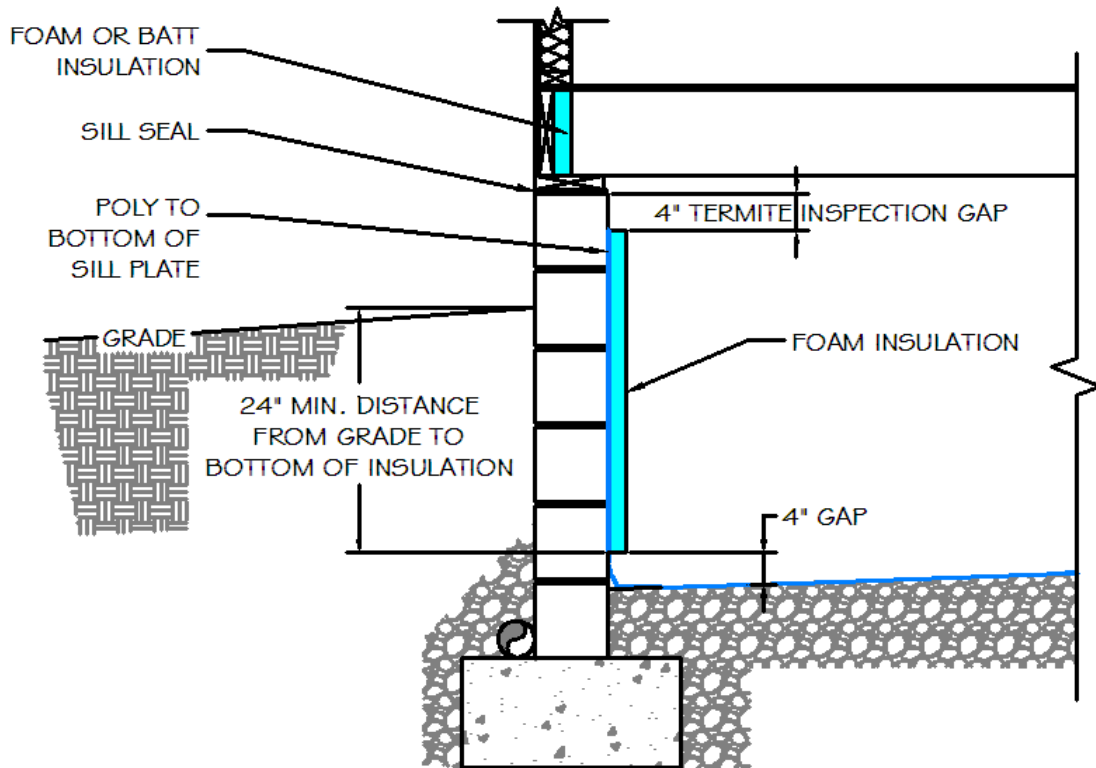

*DISCLAIMER: This material was prepared by North Carolina Energy Efficiency Alliance, a nonprofit organization. Neither the NCEEA, its member organizations, the acknowledged individuals, nor any person acting on behalf of them: (a) makes any warranty, express or implied, with respect to the use of any information, apparatus, method or process disclosed in this publication that such use may not infringe privately owned rights; or (b) assumes any liability with respect to the use of, or for direct or consequential damages resulting from the use of, any information, apparatus, method or process disclosed in this publication; or (c) has any liability for damages that result from any negligent act or omission involved in the preparation of the material. Any implied warranty of merchantability or fitness for a particular use is specifically excluded.*

## 1.2 Sealed Crawlspace Insulate Floor

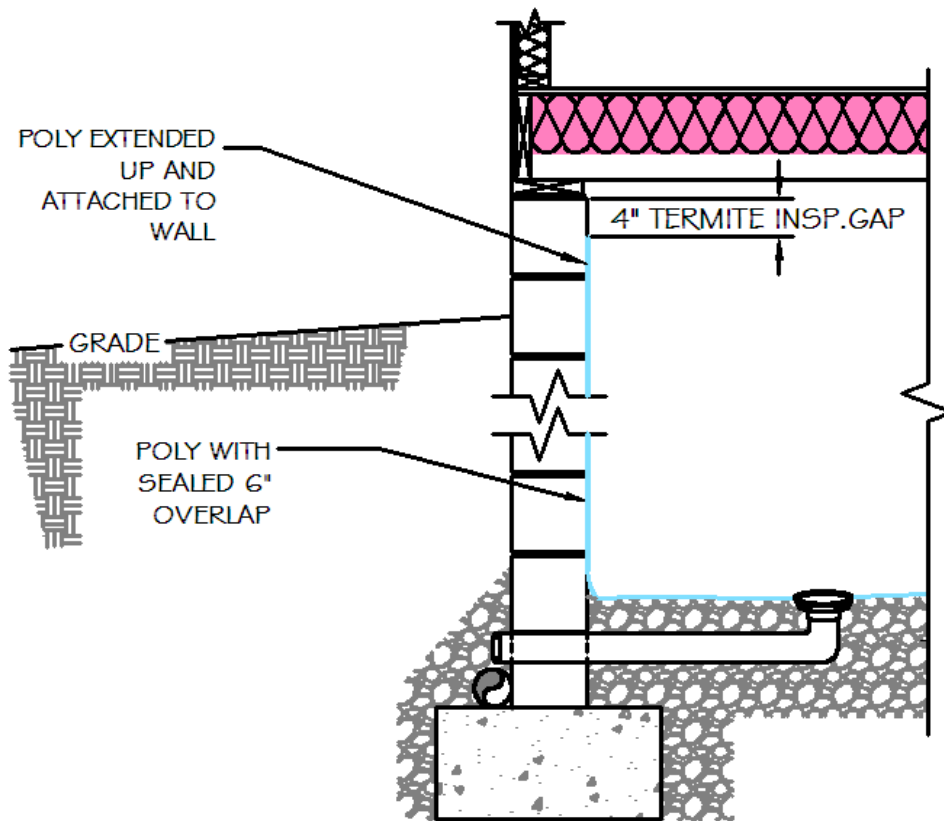

*DISCLAIMER: This material was prepared by North Carolina Energy Efficiency Alliance, a nonprofit organization. Neither the NCEEA, its member organizations, the acknowledged individuals, nor any person acting on behalf of them: (a) makes any warranty, express or implied, with respect to the use of any information, apparatus, method or process disclosed in this publication that such use may not infringe privately owned rights; or (b) assumes any liability with respect to the use of, or for direct or consequential damages resulting from the use of, any information, apparatus, method or process disclosed in this publication; or (c) has any liability for damages that result from any negligent act or omission involved in the preparation of the material. Any implied warranty of merchantability or fitness for a particular use is specifically excluded.*

## 2. Framing Details

### 2.1 Ladder Framing

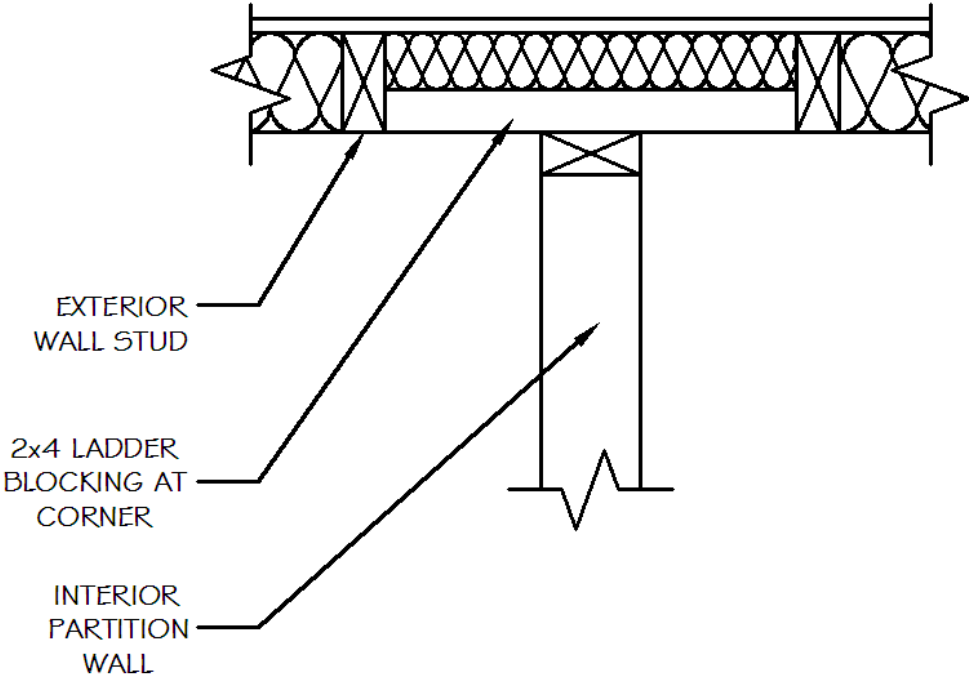

*DISCLAIMER: This material was prepared by North Carolina Energy Efficiency Alliance, a nonprofit organization. Neither the NCEEA, its member organizations, the acknowledged individuals, nor any person acting on behalf of them: (a) makes any warranty, express or implied, with respect to the use of any information, apparatus, method or process disclosed in this publication that such use may not infringe privately owned rights; or (b) assumes any liability with respect to the use of, or for direct or consequential damages resulting from the use of, any information, apparatus, method or process disclosed in this publication; or (c) has any liability for damages that result from any negligent act or omission involved in the preparation of the material. Any implied warranty of merchantability or fitness for a particular use is specifically excluded.*

## 2.1 Ladder Framing

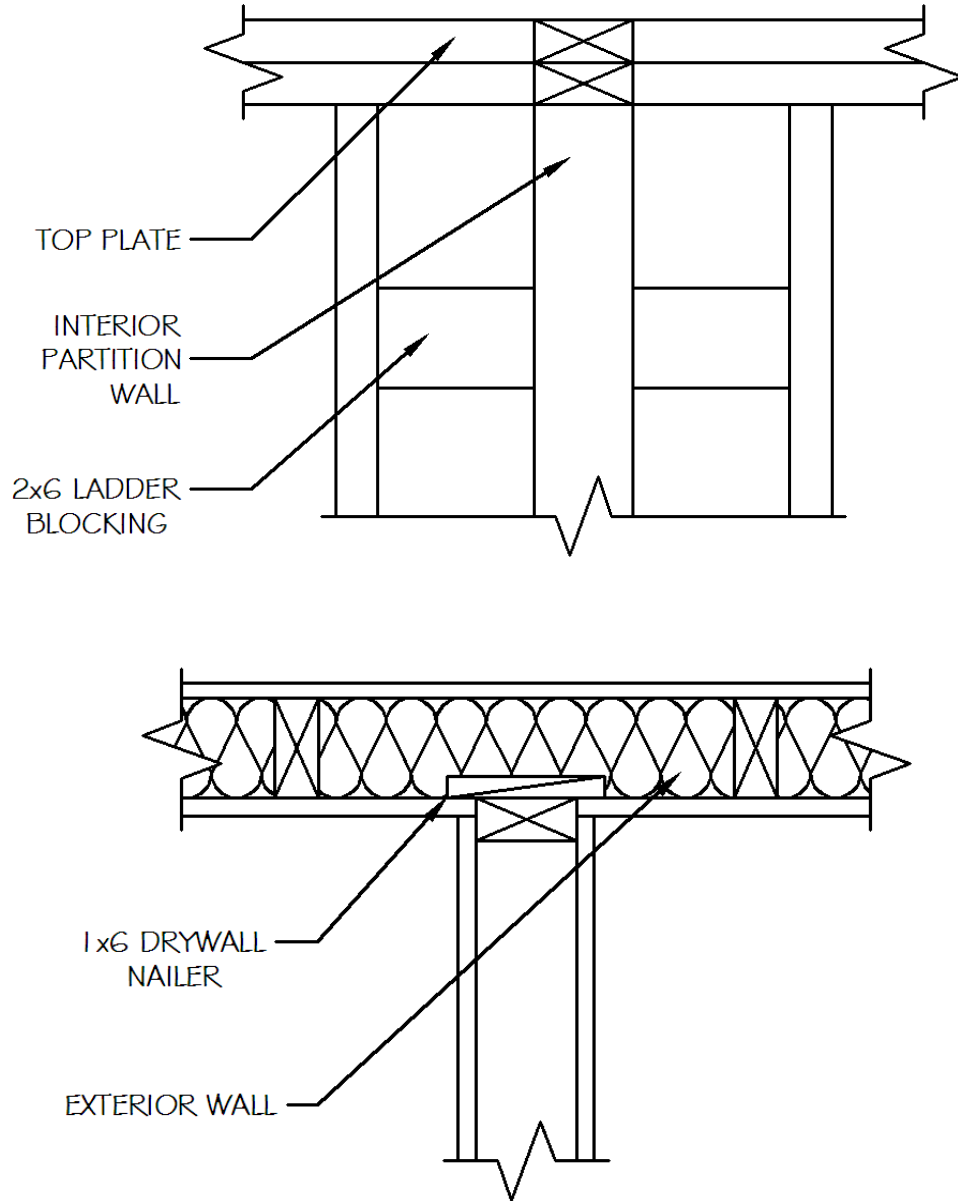

*DISCLAIMER: This material was prepared by North Carolina Energy Efficiency Alliance, a nonprofit organization. Neither the NCEEA, its member organizations, the acknowledged individuals, nor any person acting on behalf of them: (a) makes any warranty, express or implied, with respect to the use of any information, apparatus, method or process disclosed in this publication that such use may not infringe privately owned rights; or (b) assumes any liability with respect to the use of, or for direct or consequential damages resulting from the use of, any information, apparatus, method or process disclosed in this publication; or (c) has any liability for damages that result from any negligent act or omission involved in the preparation of the material. Any implied warranty of merchantability or fitness for a particular use is specifically excluded.*

## 2.3 Two-stud Corners

### 2.3.1 Metal Drywall Clips

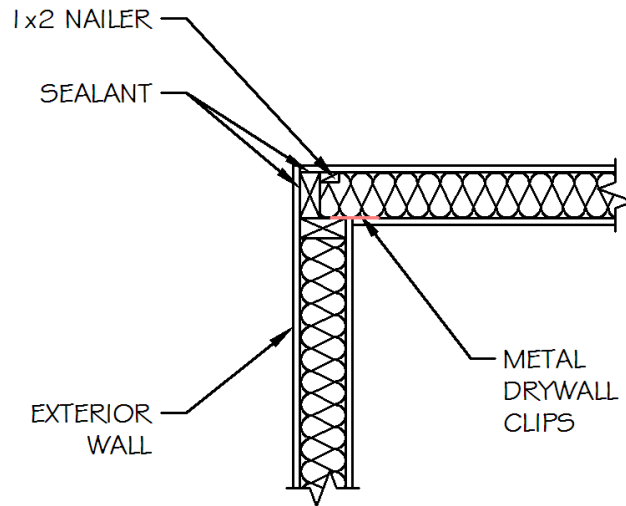

*DISCLAIMER: This material was prepared by North Carolina Energy Efficiency Alliance, a nonprofit organization. Neither the NCEEA, its member organizations, the acknowledged individuals, nor any person acting on behalf of them: (a) makes any warranty, express or implied, with respect to the use of any information, apparatus, method or process disclosed in this publication that such use may not infringe privately owned rights; or (b) assumes any liability with respect to the use of, or for direct or consequential damages resulting from the use of, any information, apparatus, method or process disclosed in this publication; or (c) has any liability for damages that result from any negligent act or omission involved in the preparation of the material. Any implied warranty of merchantability or fitness for a particular use is specifically excluded.*

### 2.3.2 Drywall Nailer – 1x4

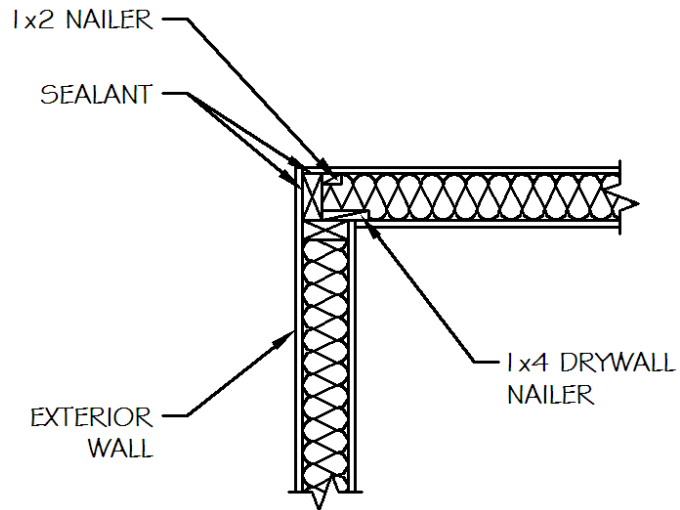

*DISCLAIMER: This material was prepared by North Carolina Energy Efficiency Alliance, a nonprofit organization. Neither the NCEEA, its member organizations, the acknowledged individuals, nor any person acting on behalf of them: (a) makes any warranty, express or implied, with respect to the use of any information, apparatus, method or process disclosed in this publication that such use may not infringe privately owned rights; or (b) assumes any liability with respect to the use of, or for direct or consequential damages resulting from the use of, any information, apparatus, method or process disclosed in this publication; or (c) has any liability for damages that result from any negligent act or omission involved in the preparation of the material. Any implied warranty of merchantability or fitness for a particular use is specifically excluded.*

## 2.4 Blocking Under Knee Wall

### 2.4.1 Truss Roof

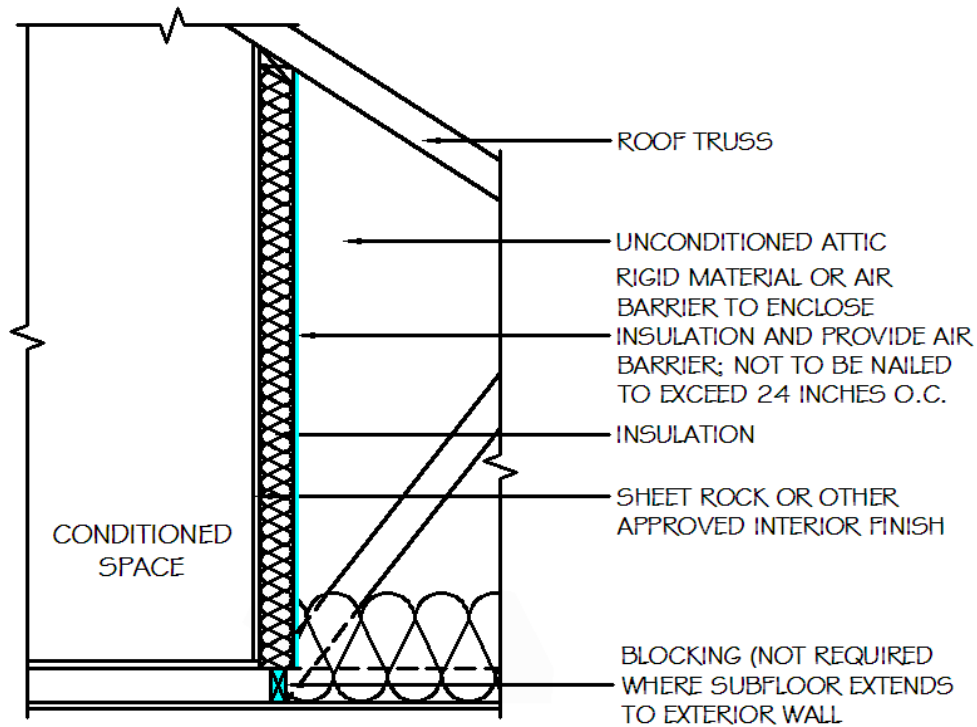

*DISCLAIMER: This material was prepared by North Carolina Energy Efficiency Alliance, a nonprofit organization. Neither the NCEEA, its member organizations, the acknowledged individuals, nor any person acting on behalf of them: (a) makes any warranty, express or implied, with respect to the use of any information, apparatus, method or process disclosed in this publication that such use may not infringe privately owned rights; or (b) assumes any liability with respect to the use of, or for direct or consequential damages resulting from the use of, any information, apparatus, method or process disclosed in this publication; or (c) has any liability for damages that result from any negligent act or omission involved in the preparation of the material. Any implied warranty of merchantability or fitness for a particular use is specifically excluded.*

### 2.4.2 Lumber Framed Attic

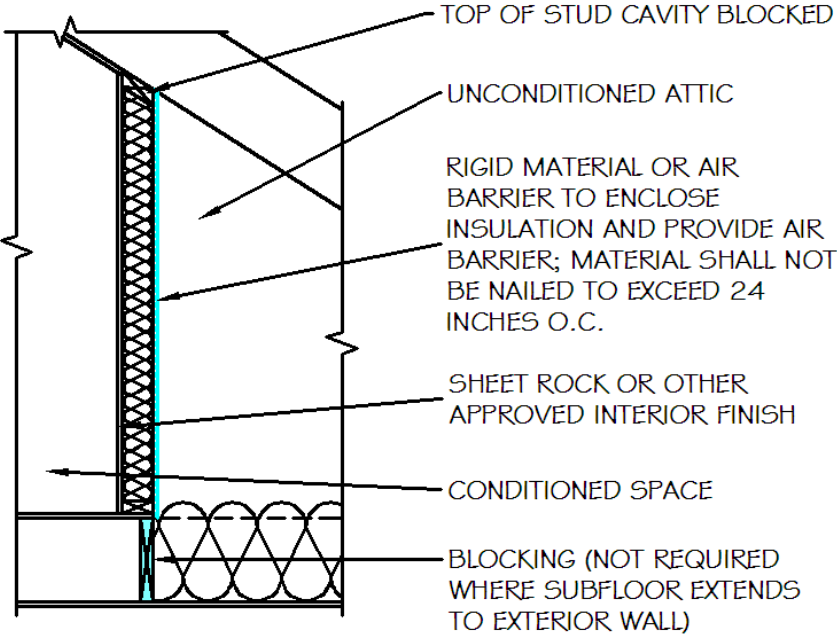

*DISCLAIMER: This material was prepared by North Carolina Energy Efficiency Alliance, a nonprofit organization. Neither the NCEEA, its member organizations, the acknowledged individuals, nor any person acting on behalf of them: (a) makes any warranty, express or implied, with respect to the use of any information, apparatus, method or process disclosed in this publication that such use may not infringe privately owned rights; or (b) assumes any liability with respect to the use of, or for direct or consequential damages resulting from the use of, any information, apparatus, method or process disclosed in this publication; or (c) has any liability for damages that result from any negligent act or omission involved in the preparation of the material. Any implied warranty of merchantability or fitness for a particular use is specifically excluded.*

## 2.5 Non-load Bearing Headers

### 2.5.1 Window Frame

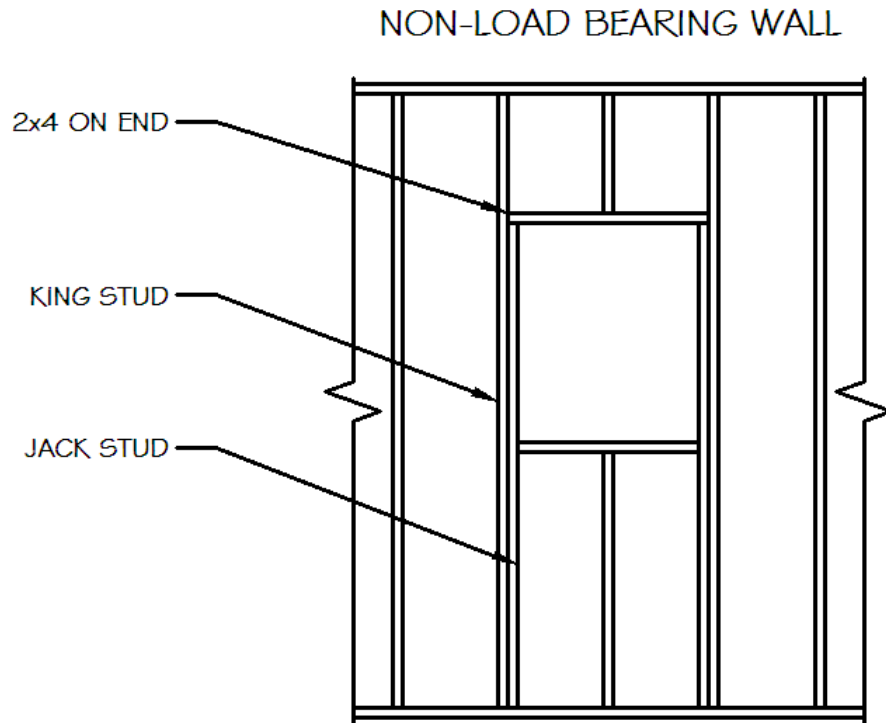

*DISCLAIMER: This material was prepared by North Carolina Energy Efficiency Alliance, a nonprofit organization. Neither the NCEEA, its member organizations, the acknowledged individuals, nor any person acting on behalf of them: (a) makes any warranty, express or implied, with respect to the use of any information, apparatus, method or process disclosed in this publication that such use may not infringe privately owned rights; or (b) assumes any liability with respect to the use of, or for direct or consequential damages resulting from the use of, any information, apparatus, method or process disclosed in this publication; or (c) has any liability for damages that result from any negligent act or omission involved in the preparation of the material. Any implied warranty of merchantability or fitness for a particular use is specifically excluded.*

## 2.5.2 Door Frame

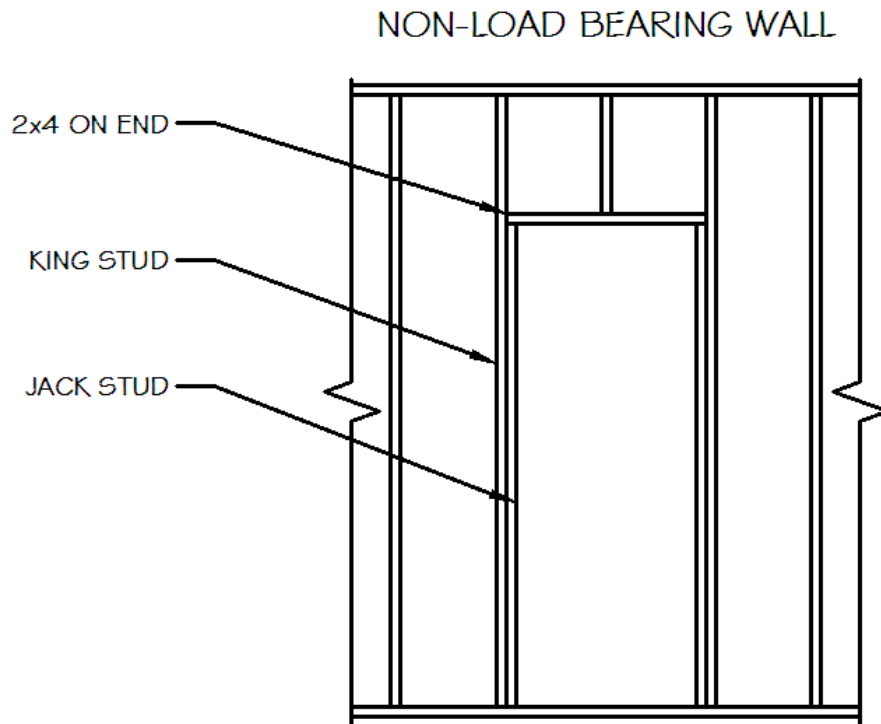

*DISCLAIMER: This material was prepared by North Carolina Energy Efficiency Alliance, a nonprofit organization. Neither the NCEEA, its member organizations, the acknowledged individuals, nor any person acting on behalf of them: (a) makes any warranty, express or implied, with respect to the use of any information, apparatus, method or process disclosed in this publication that such use may not infringe privately owned rights; or (b) assumes any liability with respect to the use of, or for direct or consequential damages resulting from the use of, any information, apparatus, method or process disclosed in this publication; or (c) has any liability for damages that result from any negligent act or omission involved in the preparation of the material. Any implied warranty of merchantability or fitness for a particular use is specifically excluded.*

## 2.6 Under Stairs

### 2.6.1 Option A

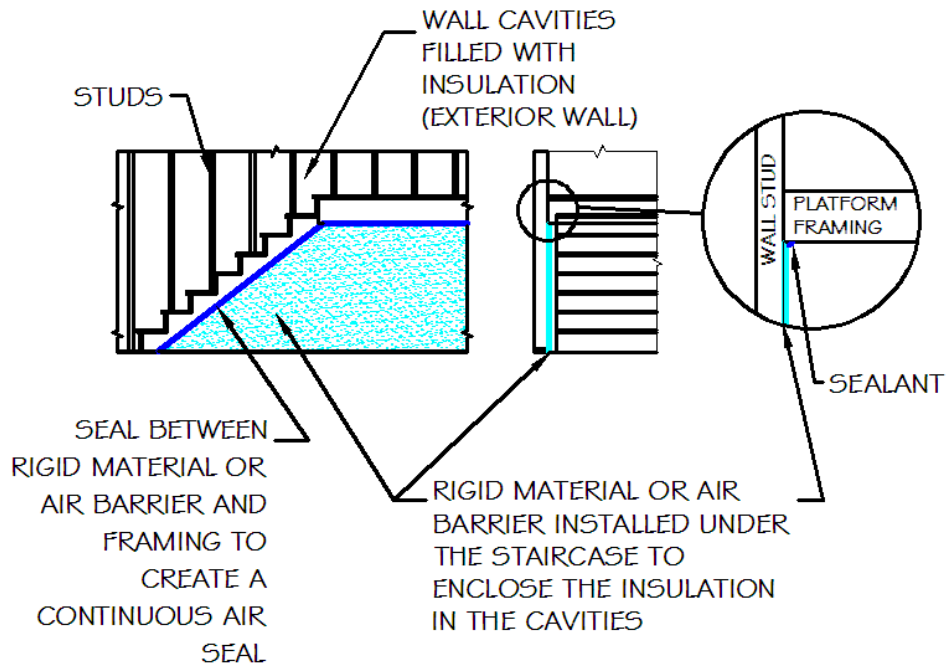

*DISCLAIMER: This material was prepared by North Carolina Energy Efficiency Alliance, a nonprofit organization. Neither the NCEEA, its member organizations, the acknowledged individuals, nor any person acting on behalf of them: (a) makes any warranty, express or implied, with respect to the use of any information, apparatus, method or process disclosed in this publication that such use may not infringe privately owned rights; or (b) assumes any liability with respect to the use of, or for direct or consequential damages resulting from the use of, any information, apparatus, method or process disclosed in this publication; or (c) has any liability for damages that result from any negligent act or omission involved in the preparation of the material. Any implied warranty of merchantability or fitness for a particular use is specifically excluded.*

2.6.2 Option B

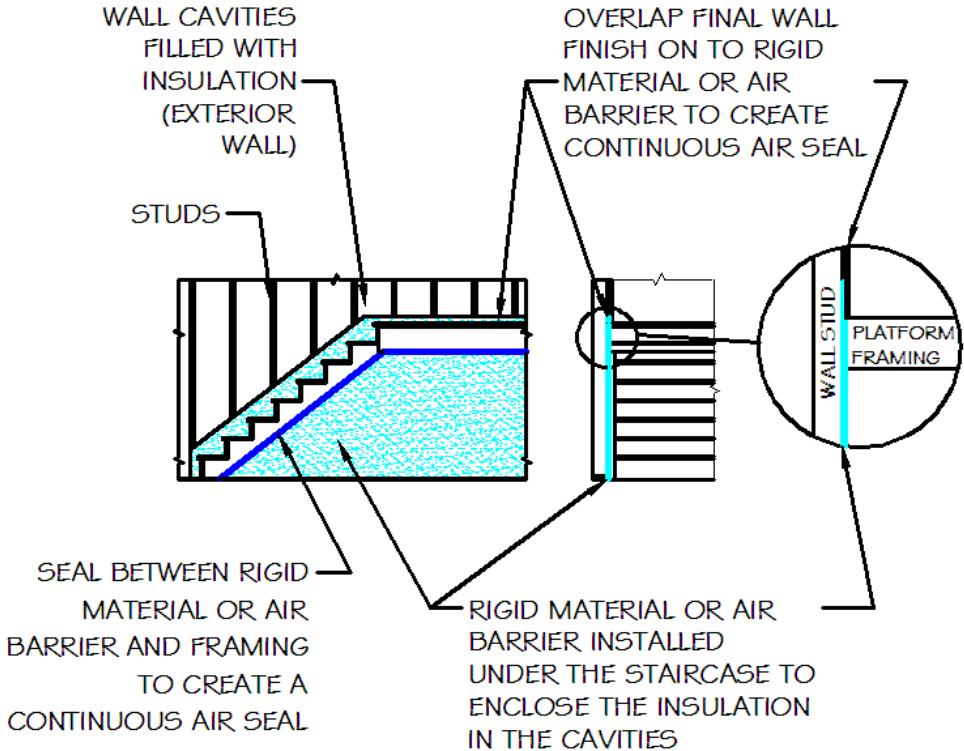

*DISCLAIMER: This material was prepared by North Carolina Energy Efficiency Alliance, a nonprofit organization. Neither the NCEEA, its member organizations, the acknowledged individuals, nor any person acting on behalf of them: (a) makes any warranty, express or implied, with respect to the use of any information, apparatus, method or process disclosed in this publication that such use may not infringe privately owned rights; or (b) assumes any liability with respect to the use of, or for direct or consequential damages resulting from the use of, any information, apparatus, method or process disclosed in this publication; or (c) has any liability for damages that result from any negligent act or omission involved in the preparation of the material. Any implied warranty of merchantability or fitness for a particular use is specifically excluded.*

## 2.7 Blocking Between Garage and Conditioned Space

### 2.7.1 Floor System → Truss

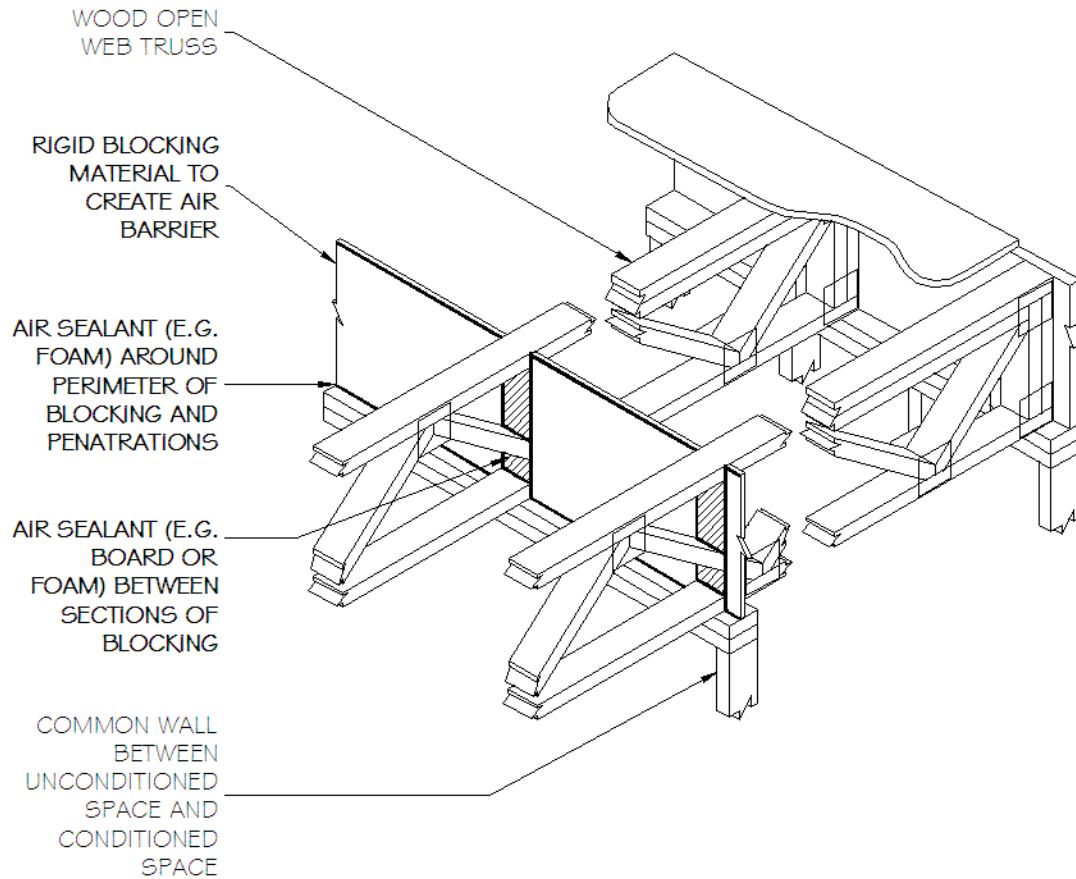

*DISCLAIMER: This material was prepared by North Carolina Energy Efficiency Alliance, a nonprofit organization. Neither the NCEEA, its member organizations, the acknowledged individuals, nor any person acting on behalf of them: (a) makes any warranty, express or implied, with respect to the use of any information, apparatus, method or process disclosed in this publication that such use may not infringe privately owned rights; or (b) assumes any liability with respect to the use of, or for direct or consequential damages resulting from the use of, any information, apparatus, method or process disclosed in this publication; or (c) has any liability for damages that result from any negligent act or omission involved in the preparation of the material. Any implied warranty of merchantability or fitness for a particular use is specifically excluded.*

## 2.7.2 Floor System → I-Joists

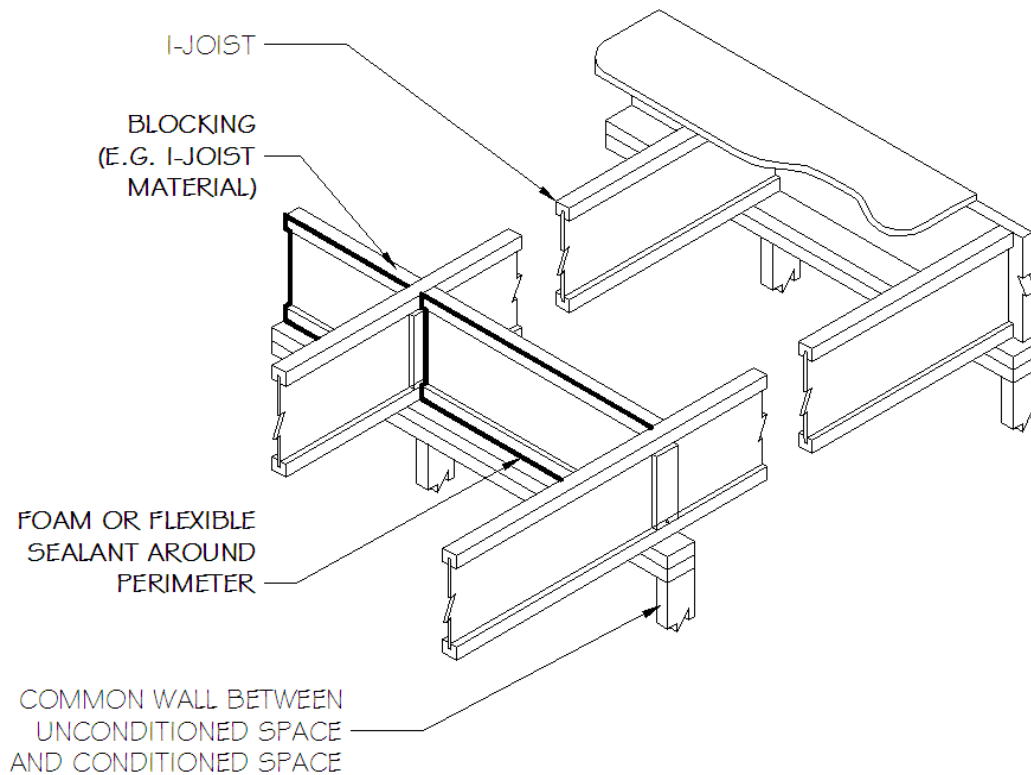

*DISCLAIMER: This material was prepared by North Carolina Energy Efficiency Alliance, a nonprofit organization. Neither the NCEEA, its member organizations, the acknowledged individuals, nor any person acting on behalf of them: (a) makes any warranty, express or implied, with respect to the use of any information, apparatus, method or process disclosed in this publication that such use may not infringe privately owned rights; or (b) assumes any liability with respect to the use of, or for direct or consequential damages resulting from the use of, any information, apparatus, method or process disclosed in this publication; or (c) has any liability for damages that result from any negligent act or omission involved in the preparation of the material. Any implied warranty of merchantability or fitness for a particular use is specifically excluded.*

### 2.7.3 Floor System → Dimensional Lumber

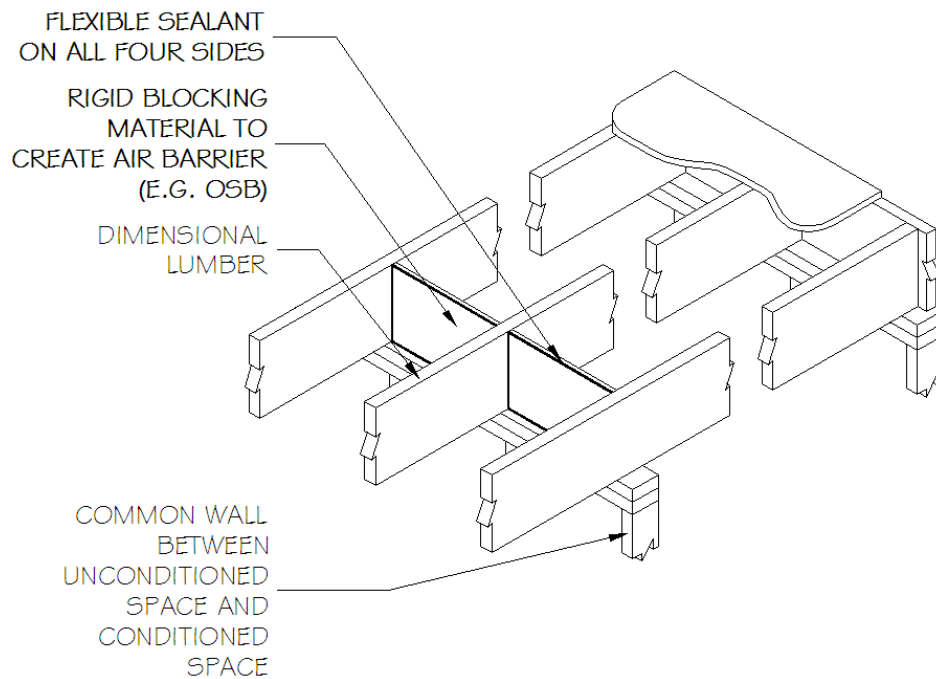

*DISCLAIMER: This material was prepared by North Carolina Energy Efficiency Alliance, a nonprofit organization. Neither the NCEEA, its member organizations, the acknowledged individuals, nor any person acting on behalf of them: (a) makes any warranty, express or implied, with respect to the use of any information, apparatus, method or process disclosed in this publication that such use may not infringe privately owned rights; or (b) assumes any liability with respect to the use of, or for direct or consequential damages resulting from the use of, any information, apparatus, method or process disclosed in this publication; or (c) has any liability for damages that result from any negligent act or omission involved in the preparation of the material. Any implied warranty of merchantability or fitness for a particular use is specifically excluded.*

## 2.8 Direct Vent Gas Fireplace

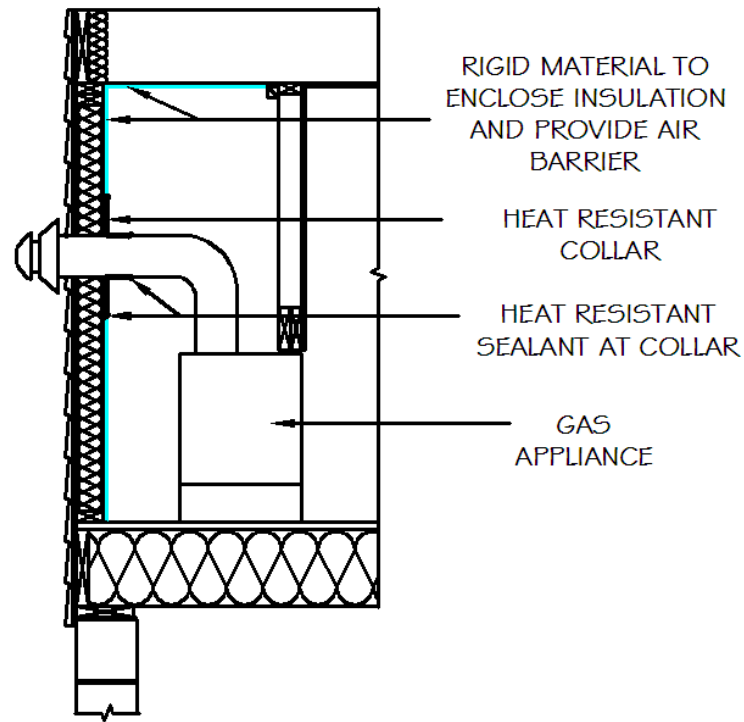

*DISCLAIMER: This material was prepared by North Carolina Energy Efficiency Alliance, a nonprofit organization. Neither the NCEEA, its member organizations, the acknowledged individuals, nor any person acting on behalf of them: (a) makes any warranty, express or implied, with respect to the use of any information, apparatus, method or process disclosed in this publication that such use may not infringe privately owned rights; or (b) assumes any liability with respect to the use of, or for direct or consequential damages resulting from the use of, any information, apparatus, method or process disclosed in this publication; or (c) has any liability for damages that result from any negligent act or omission involved in the preparation of the material. Any implied warranty of merchantability or fitness for a particular use is specifically excluded.*

## 2.8 Direct Vent Gas Fireplace

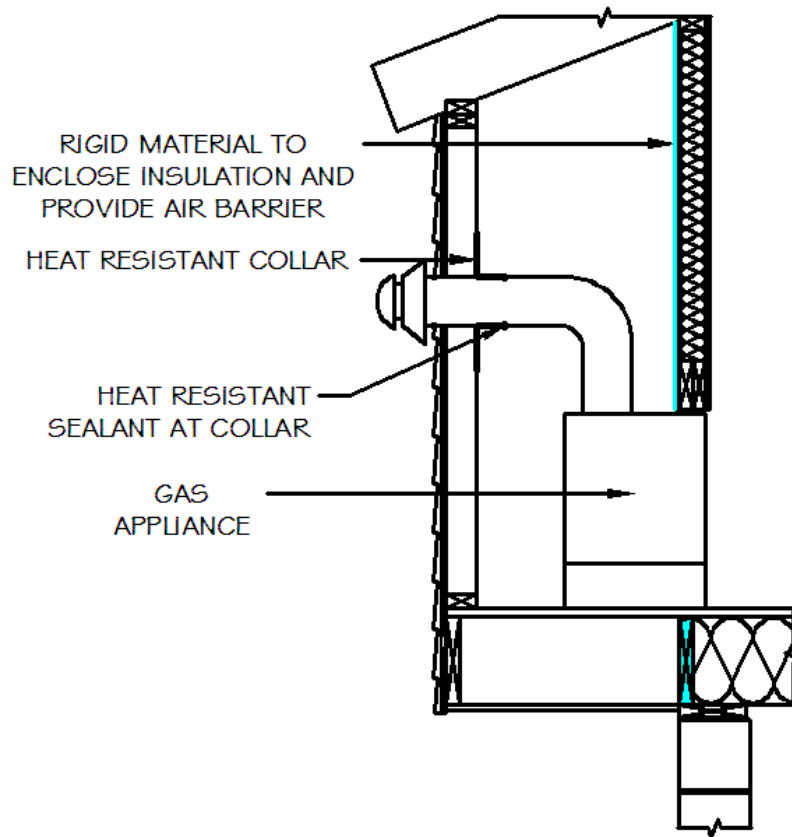

*DISCLAIMER: This material was prepared by North Carolina Energy Efficiency Alliance, a nonprofit organization. Neither the NCEEA, its member organizations, the acknowledged individuals, nor any person acting on behalf of them: (a) makes any warranty, express or implied, with respect to the use of any information, apparatus, method or process disclosed in this publication that such use may not infringe privately owned rights; or (b) assumes any liability with respect to the use of, or for direct or consequential damages resulting from the use of, any information, apparatus, method or process disclosed in this publication; or (c) has any liability for damages that result from any negligent act or omission involved in the preparation of the material. Any implied warranty of merchantability or fitness for a particular use is specifically excluded.*

## 2.9 Soffit Over Cabinets

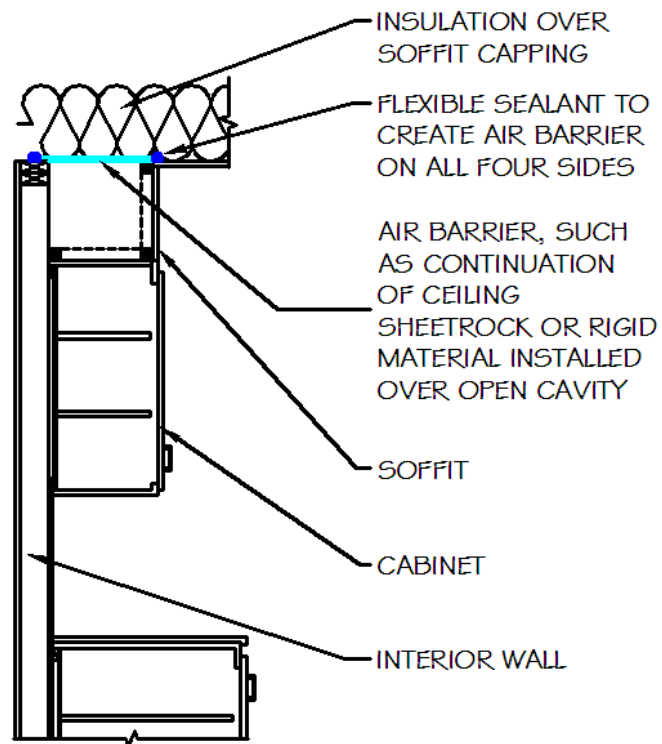

*DISCLAIMER: This material was prepared by North Carolina Energy Efficiency Alliance, a nonprofit organization. Neither the NCEEA, its member organizations, the acknowledged individuals, nor any person acting on behalf of them: (a) makes any warranty, express or implied, with respect to the use of any information, apparatus, method or process disclosed in this publication that such use may not infringe privately owned rights; or (b) assumes any liability with respect to the use of, or for direct or consequential damages resulting from the use of, any information, apparatus, method or process disclosed in this publication; or (c) has any liability for damages that result from any negligent act or omission involved in the preparation of the material. Any implied warranty of merchantability or fitness for a particular use is specifically excluded.*

## 2.10 Bathtub on Exterior Wall

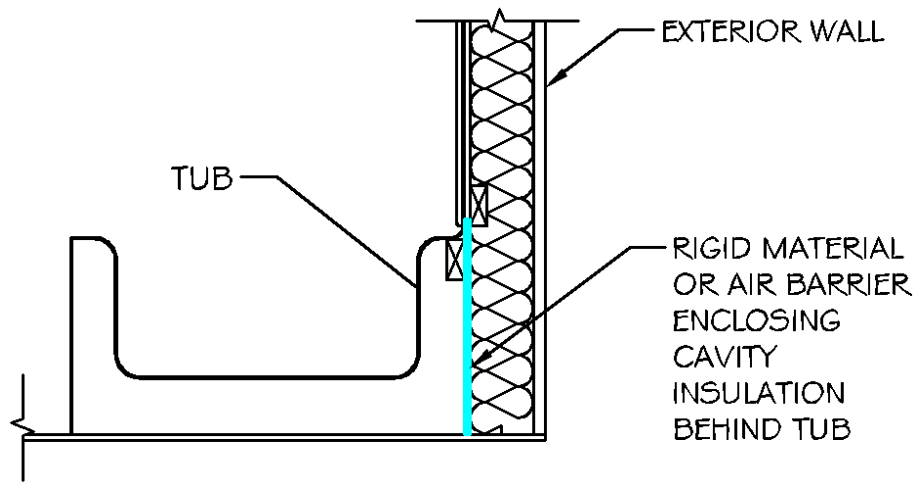

*DISCLAIMER: This material was prepared by North Carolina Energy Efficiency Alliance, a nonprofit organization. Neither the NCEEA, its member organizations, the acknowledged individuals, nor any person acting on behalf of them: (a) makes any warranty, express or implied, with respect to the use of any information, apparatus, method or process disclosed in this publication that such use may not infringe privately owned rights; or (b) assumes any liability with respect to the use of, or for direct or consequential damages resulting from the use of, any information, apparatus, method or process disclosed in this publication; or (c) has any liability for damages that result from any negligent act or omission involved in the preparation of the material. Any implied warranty of merchantability or fitness for a particular use is specifically excluded.*

## 2.11 Showers on Exterior Wall

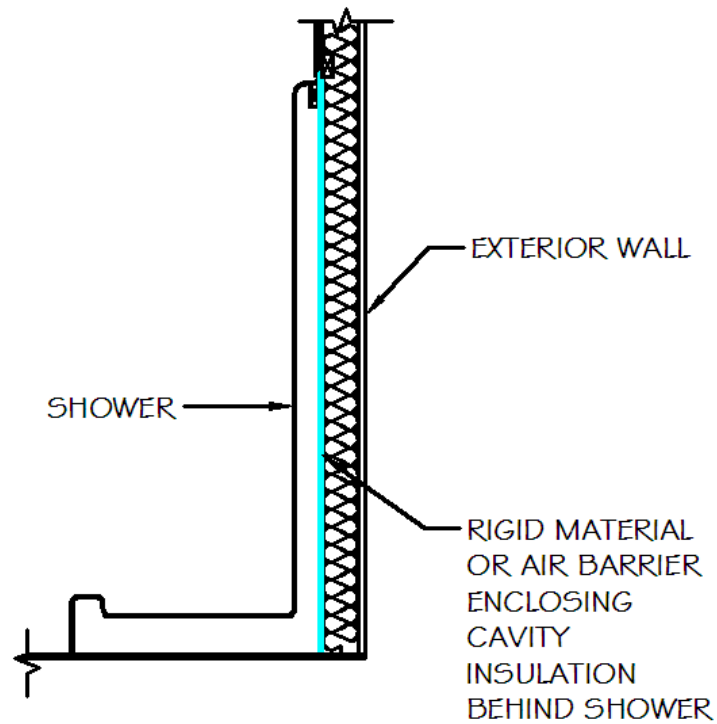

*DISCLAIMER: This material was prepared by North Carolina Energy Efficiency Alliance, a nonprofit organization. Neither the NCEEA, its member organizations, the acknowledged individuals, nor any person acting on behalf of them: (a) makes any warranty, express or implied, with respect to the use of any information, apparatus, method or process disclosed in this publication that such use may not infringe privately owned rights; or (b) assumes any liability with respect to the use of, or for direct or consequential damages resulting from the use of, any information, apparatus, method or process disclosed in this publication; or (c) has any liability for damages that result from any negligent act or omission involved in the preparation of the material. Any implied warranty of merchantability or fitness for a particular use is specifically excluded.*

## 2.12 Capped Mechanical Chase

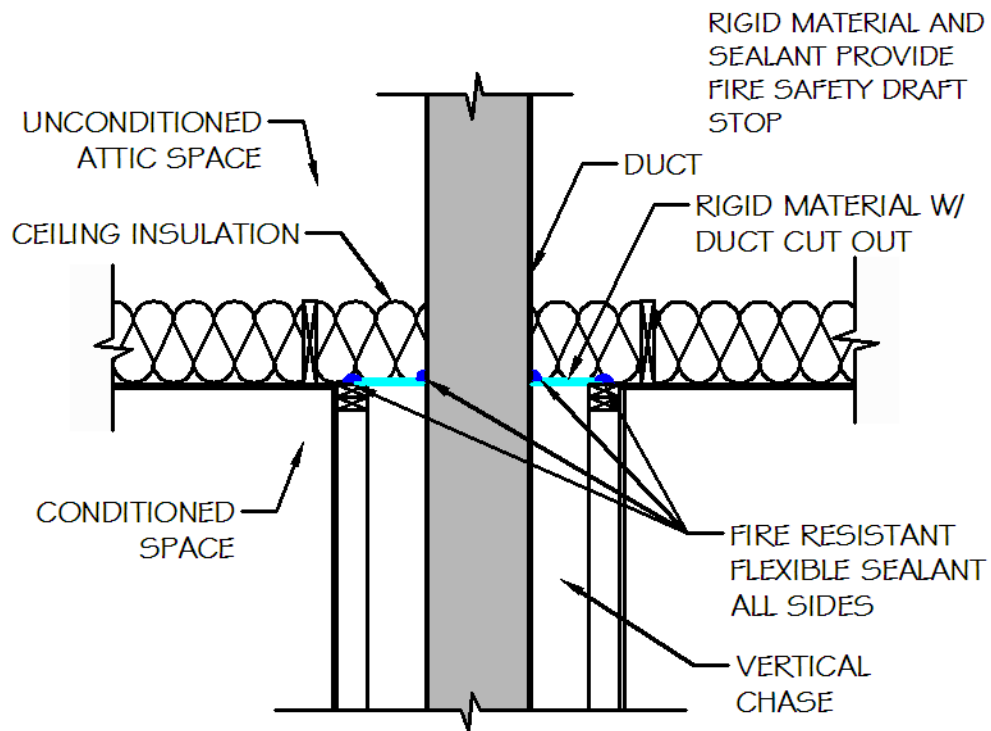

*DISCLAIMER: This material was prepared by North Carolina Energy Efficiency Alliance, a nonprofit organization. Neither the NCEEA, its member organizations, the acknowledged individuals, nor any person acting on behalf of them: (a) makes any warranty, express or implied, with respect to the use of any information, apparatus, method or process disclosed in this publication that such use may not infringe privately owned rights; or (b) assumes any liability with respect to the use of, or for direct or consequential damages resulting from the use of, any information, apparatus, method or process disclosed in this publication; or (c) has any liability for damages that result from any negligent act or omission involved in the preparation of the material. Any implied warranty of merchantability or fitness for a particular use is specifically excluded.*

## 2.13 Sealed Supply Duct

### 2.13.1 Duct in Floor System

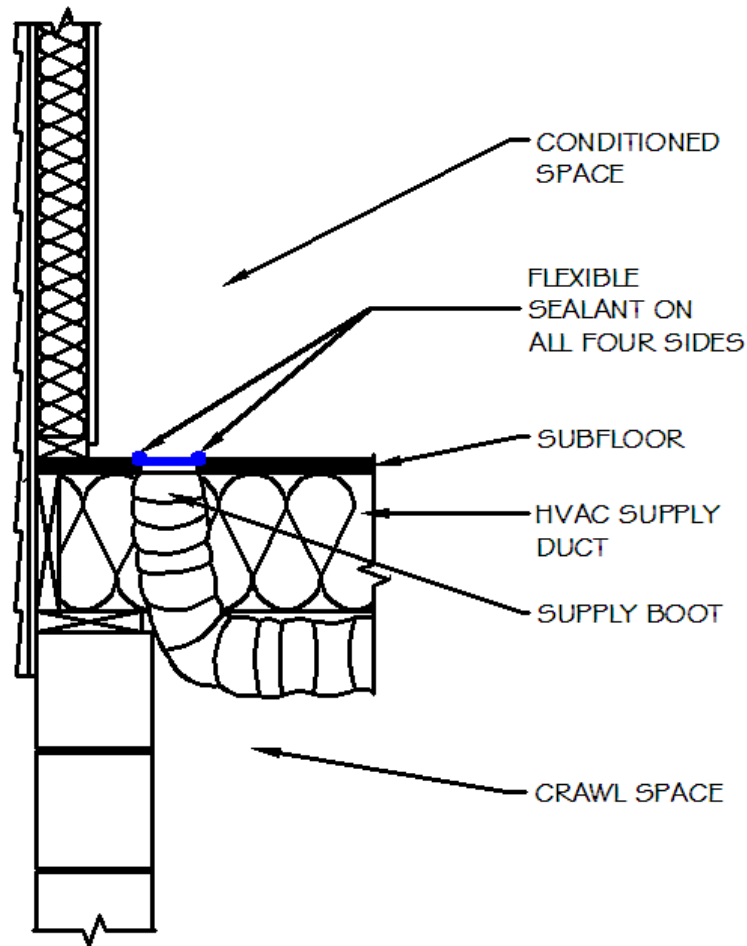

*DISCLAIMER: This material was prepared by North Carolina Energy Efficiency Alliance, a nonprofit organization. Neither the NCEEA, its member organizations, the acknowledged individuals, nor any person acting on behalf of them: (a) makes any warranty, express or implied, with respect to the use of any information, apparatus, method or process disclosed in this publication that such use may not infringe privately owned rights; or (b) assumes any liability with respect to the use of, or for direct or consequential damages resulting from the use of, any information, apparatus, method or process disclosed in this publication; or (c) has any liability for damages that result from any negligent act or omission involved in the preparation of the material. Any implied warranty of merchantability or fitness for a particular use is specifically excluded.*

### 2.13.2 Duct in Ceiling

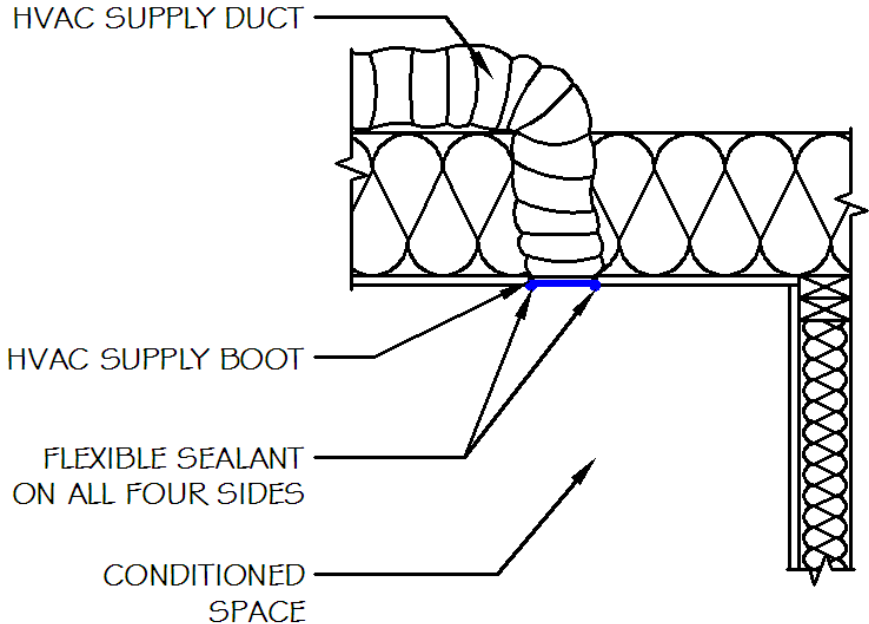

*DISCLAIMER: This material was prepared by North Carolina Energy Efficiency Alliance, a nonprofit organization. Neither the NCEEA, its member organizations, the acknowledged individuals, nor any person acting on behalf of them: (a) makes any warranty, express or implied, with respect to the use of any information, apparatus, method or process disclosed in this publication that such use may not infringe privately owned rights; or (b) assumes any liability with respect to the use of, or for direct or consequential damages resulting from the use of, any information, apparatus, method or process disclosed in this publication; or (c) has any liability for damages that result from any negligent act or omission involved in the preparation of the material. Any implied warranty of merchantability or fitness for a particular use is specifically excluded.*

## 2.14 Raised Roof Assembly

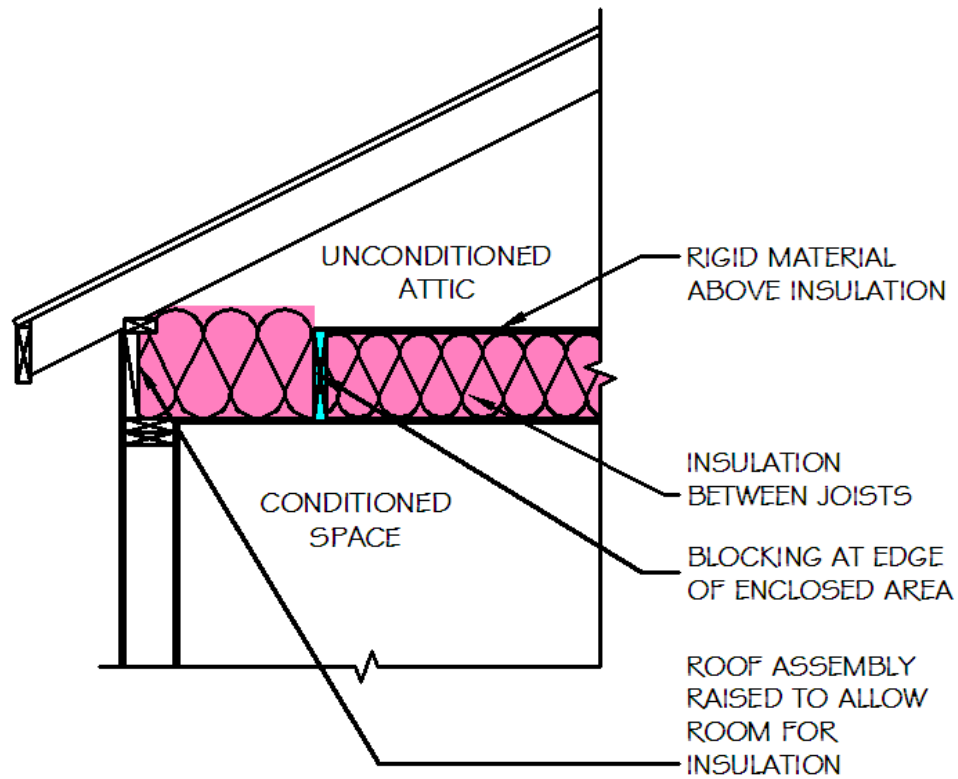

*DISCLAIMER: This material was prepared by North Carolina Energy Efficiency Alliance, a nonprofit organization. Neither the NCEEA, its member organizations, the acknowledged individuals, nor any person acting on behalf of them: (a) makes any warranty, express or implied, with respect to the use of any information, apparatus, method or process disclosed in this publication that such use may not infringe privately owned rights; or (b) assumes any liability with respect to the use of, or for direct or consequential damages resulting from the use of, any information, apparatus, method or process disclosed in this publication; or (c) has any liability for damages that result from any negligent act or omission involved in the preparation of the material. Any implied warranty of merchantability or fitness for a particular use is specifically excluded.*

### 3. Sealing Details

#### 3.1 Floor Penetrations

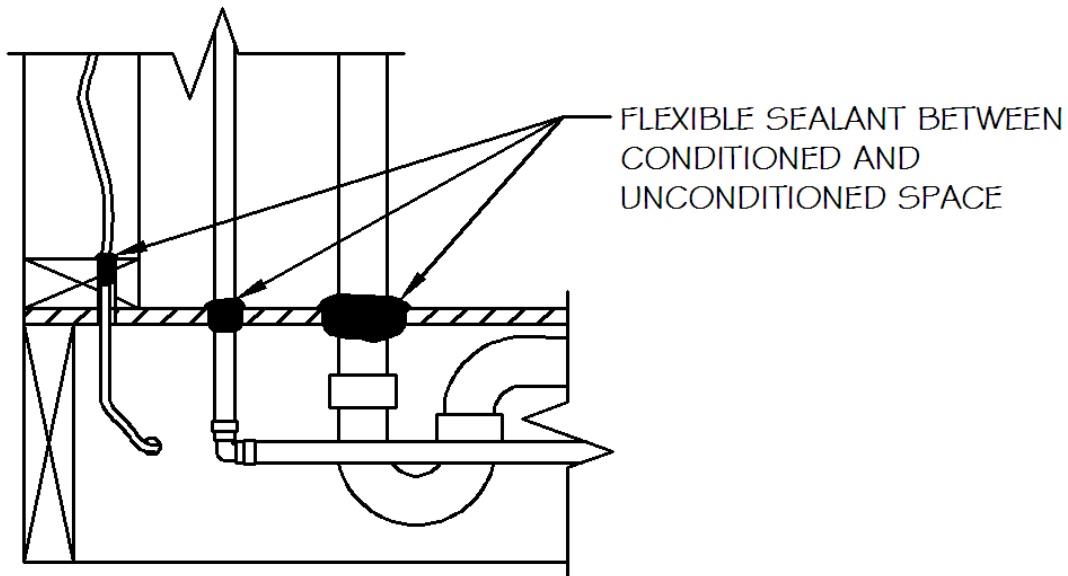

*DISCLAIMER: This material was prepared by North Carolina Energy Efficiency Alliance, a nonprofit organization. Neither the NCEEA, its member organizations, the acknowledged individuals, nor any person acting on behalf of them: (a) makes any warranty, express or implied, with respect to the use of any information, apparatus, method or process disclosed in this publication that such use may not infringe privately owned rights; or (b) assumes any liability with respect to the use of, or for direct or consequential damages resulting from the use of, any information, apparatus, method or process disclosed in this publication; or (c) has any liability for damages that result from any negligent act or omission involved in the preparation of the material. Any implied warranty of merchantability or fitness for a particular use is specifically excluded.*

## 3.2 Wall Penetrations

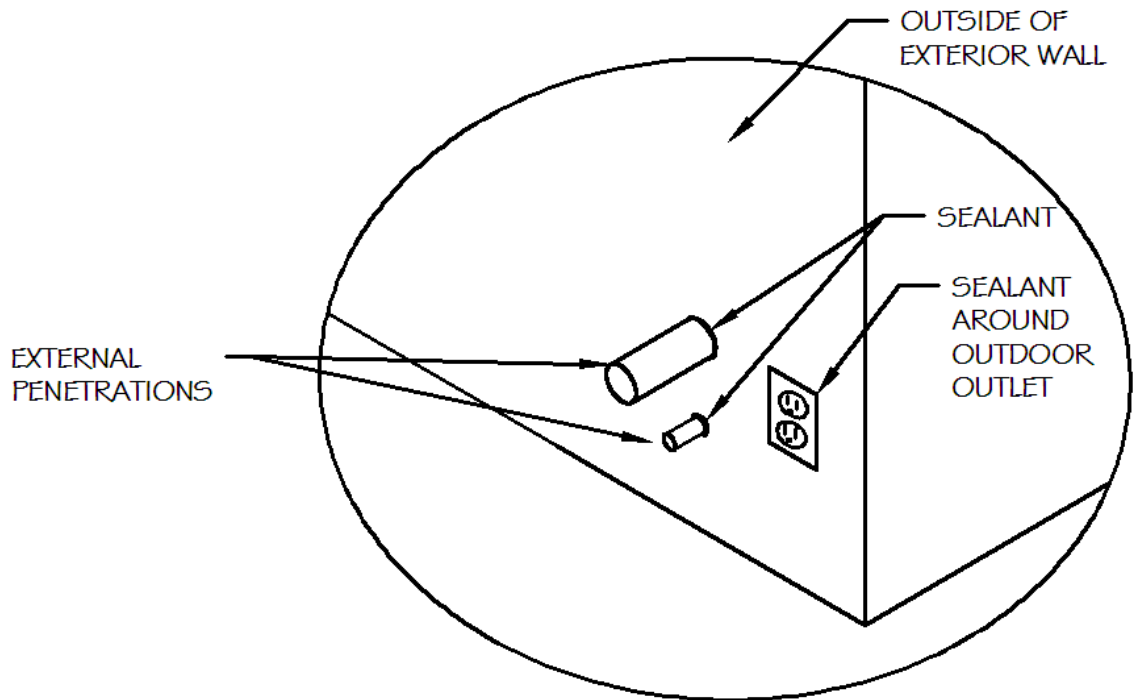

*DISCLAIMER: This material was prepared by North Carolina Energy Efficiency Alliance, a nonprofit organization. Neither the NCEEA, its member organizations, the acknowledged individuals, nor any person acting on behalf of them: (a) makes any warranty, express or implied, with respect to the use of any information, apparatus, method or process disclosed in this publication that such use may not infringe privately owned rights; or (b) assumes any liability with respect to the use of, or for direct or consequential damages resulting from the use of, any information, apparatus, method or process disclosed in this publication; or (c) has any liability for damages that result from any negligent act or omission involved in the preparation of the material. Any implied warranty of merchantability or fitness for a particular use is specifically excluded.*

### 3.3 Sealing Electrical Boxes

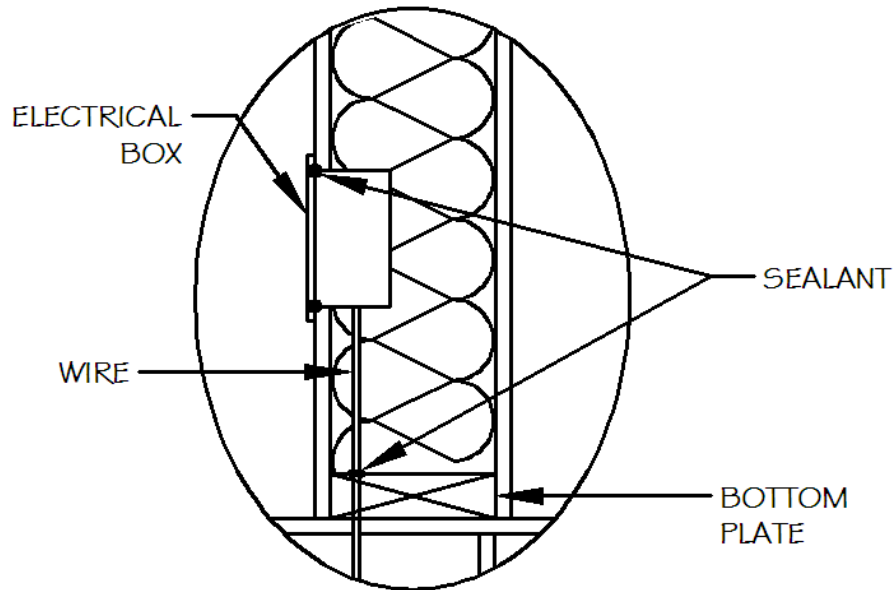

*DISCLAIMER: This material was prepared by North Carolina Energy Efficiency Alliance, a nonprofit organization. Neither the NCEEA, its member organizations, the acknowledged individuals, nor any person acting on behalf of them: (a) makes any warranty, express or implied, with respect to the use of any information, apparatus, method or process disclosed in this publication that such use may not infringe privately owned rights; or (b) assumes any liability with respect to the use of, or for direct or consequential damages resulting from the use of, any information, apparatus, method or process disclosed in this publication; or (c) has any liability for damages that result from any negligent act or omission involved in the preparation of the material. Any implied warranty of merchantability or fitness for a particular use is specifically excluded.*

## 4. Water Management Details

### 4.1 Step Flashing

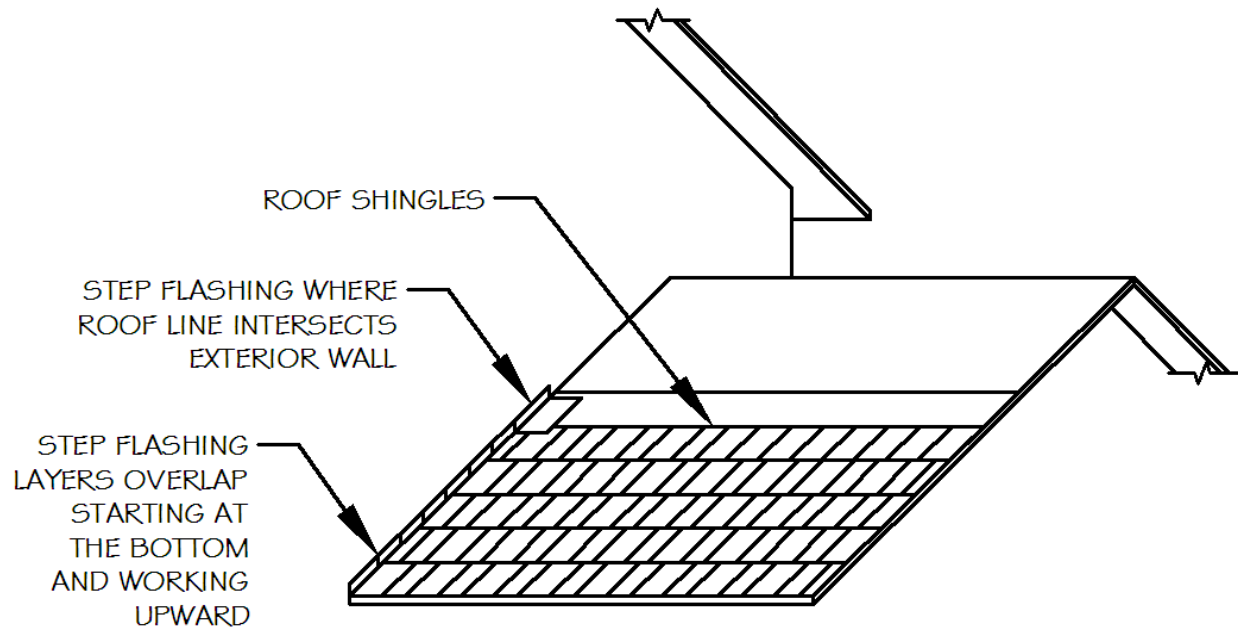

*DISCLAIMER: This material was prepared by North Carolina Energy Efficiency Alliance, a nonprofit organization. Neither the NCEEA, its member organizations, the acknowledged individuals, nor any person acting on behalf of them: (a) makes any warranty, express or implied, with respect to the use of any information, apparatus, method or process disclosed in this publication that such use may not infringe privately owned rights; or (b) assumes any liability with respect to the use of, or for direct or consequential damages resulting from the use of, any information, apparatus, method or process disclosed in this publication; or (c) has any liability for damages that result from any negligent act or omission involved in the preparation of the material. Any implied warranty of merchantability or fitness for a particular use is specifically excluded.*

## 4.2 Step Flashing

### MORE ROOF FLASHING DETAILS ...

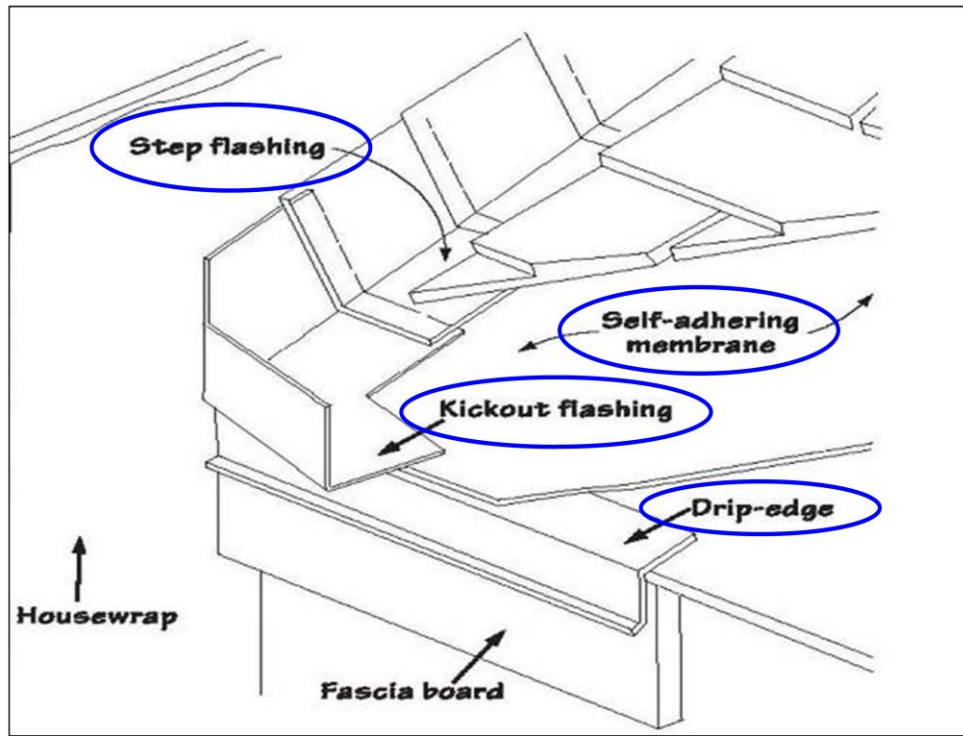

*DISCLAIMER: This material was prepared by North Carolina Energy Efficiency Alliance, a nonprofit organization. Neither the NCEEA, its member organizations, the acknowledged individuals, nor any person acting on behalf of them: (a) makes any warranty, express or implied, with respect to the use of any information, apparatus, method or process disclosed in this publication that such use may not infringe privately owned rights; or (b) assumes any liability with respect to the use of, or for direct or consequential damages resulting from the use of, any information, apparatus, method or process disclosed in this publication; or (c) has any liability for damages that result from any negligent act or omission involved in the preparation of the material. Any implied warranty of merchantability or fitness for a particular use is specifically excluded.*

### 4.3 Window Flashing

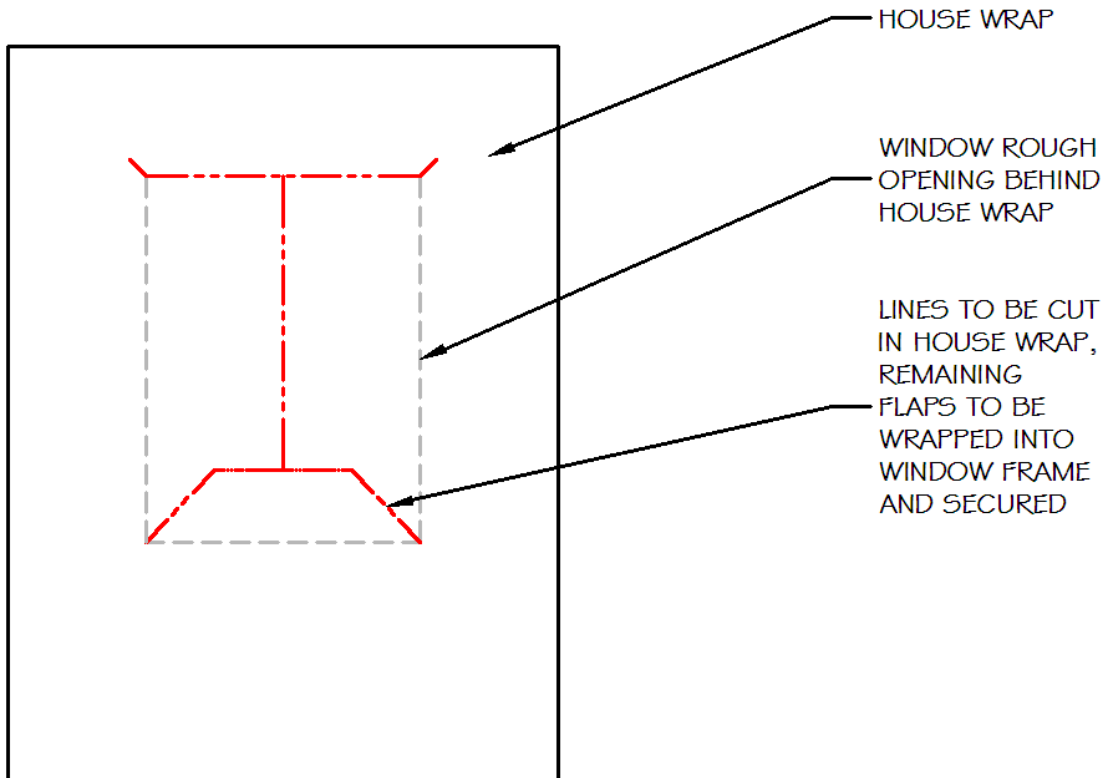

*DISCLAIMER: This material was prepared by North Carolina Energy Efficiency Alliance, a nonprofit organization. Neither the NCEEA, its member organizations, the acknowledged individuals, nor any person acting on behalf of them: (a) makes any warranty, express or implied, with respect to the use of any information, apparatus, method or process disclosed in this publication that such use may not infringe privately owned rights; or (b) assumes any liability with respect to the use of, or for direct or consequential damages resulting from the use of, any information, apparatus, method or process disclosed in this publication; or (c) has any liability for damages that result from any negligent act or omission involved in the preparation of the material. Any implied warranty of merchantability or fitness for a particular use is specifically excluded.*

### 4.3 Window Flashing

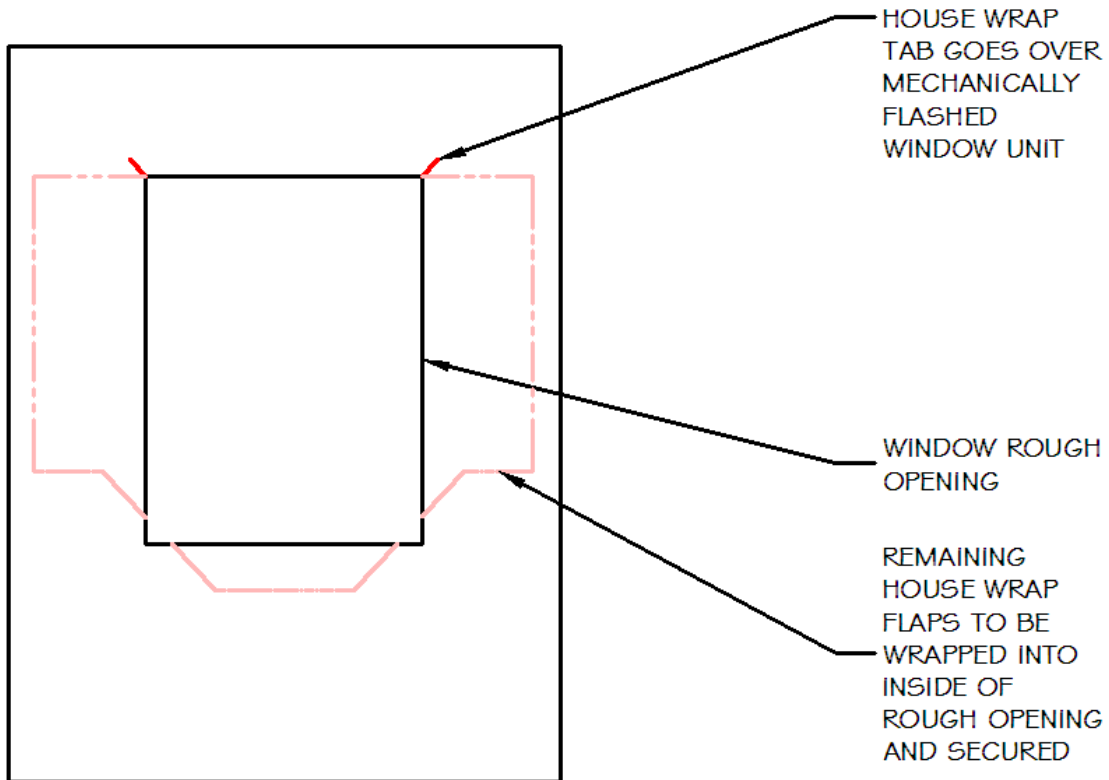

*DISCLAIMER: This material was prepared by North Carolina Energy Efficiency Alliance, a nonprofit organization. Neither the NCEEA, its member organizations, the acknowledged individuals, nor any person acting on behalf of them: (a) makes any warranty, express or implied, with respect to the use of any information, apparatus, method or process disclosed in this publication that such use may not infringe privately owned rights; or (b) assumes any liability with respect to the use of, or for direct or consequential damages resulting from the use of, any information, apparatus, method or process disclosed in this publication; or (c) has any liability for damages that result from any negligent act or omission involved in the preparation of the material. Any implied warranty of merchantability or fitness for a particular use is specifically excluded.*

### 4.3 Window Flashing

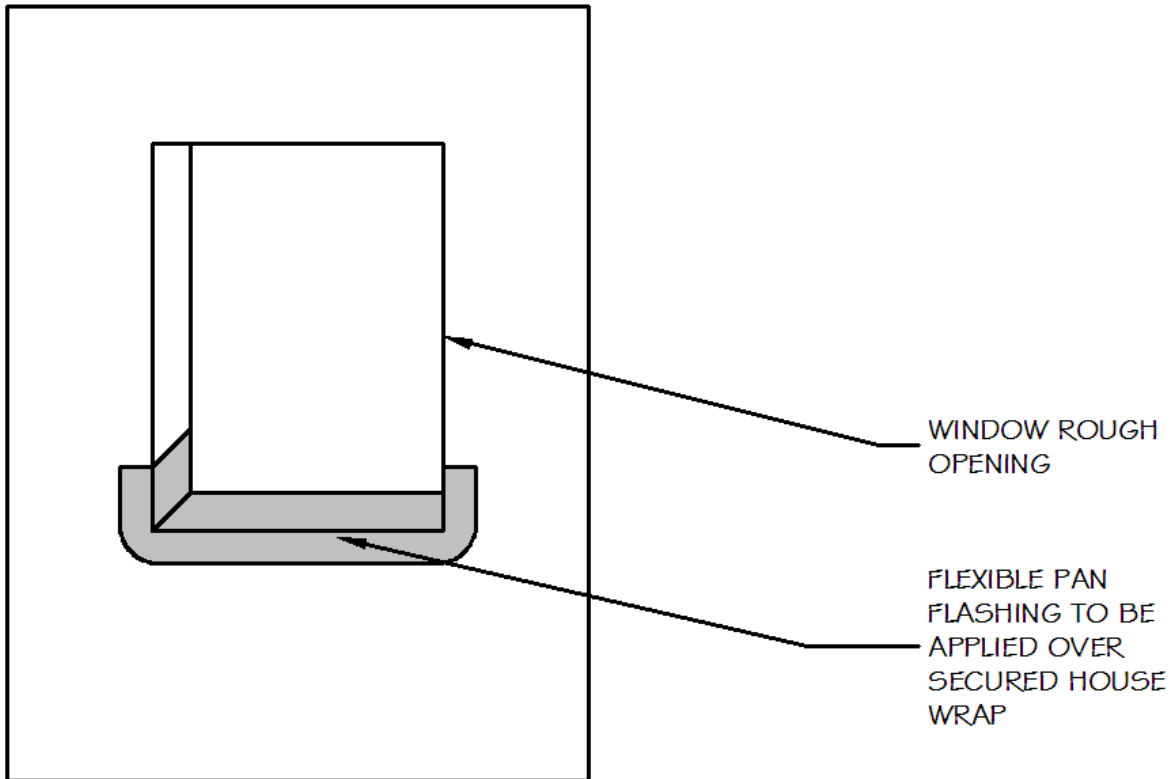

*DISCLAIMER: This material was prepared by North Carolina Energy Efficiency Alliance, a nonprofit organization. Neither the NCEEA, its member organizations, the acknowledged individuals, nor any person acting on behalf of them: (a) makes any warranty, express or implied, with respect to the use of any information, apparatus, method or process disclosed in this publication that such use may not infringe privately owned rights; or (b) assumes any liability with respect to the use of, or for direct or consequential damages resulting from the use of, any information, apparatus, method or process disclosed in this publication; or (c) has any liability for damages that result from any negligent act or omission involved in the preparation of the material. Any implied warranty of merchantability or fitness for a particular use is specifically excluded.*

## 4.4 Drain Plane Installation

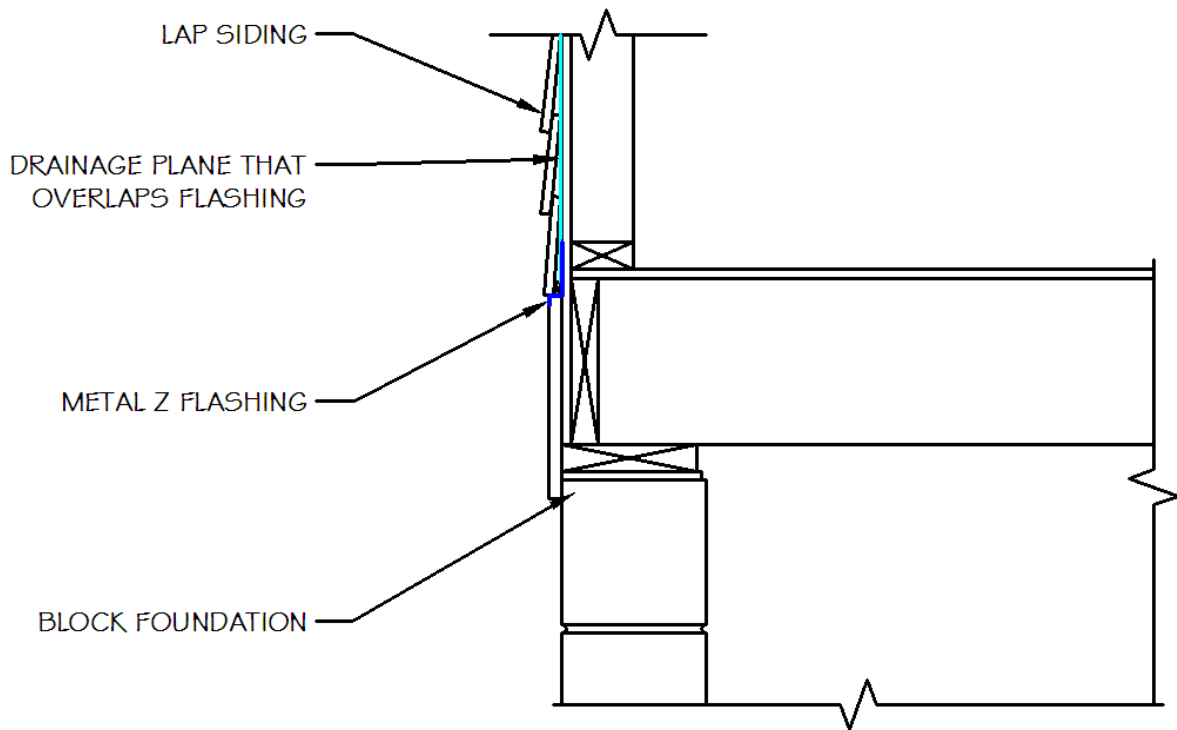

*DISCLAIMER: This material was prepared by North Carolina Energy Efficiency Alliance, a nonprofit organization. Neither the NCEEA, its member organizations, the acknowledged individuals, nor any person acting on behalf of them: (a) makes any warranty, express or implied, with respect to the use of any information, apparatus, method or process disclosed in this publication that such use may not infringe privately owned rights; or (b) assumes any liability with respect to the use of, or for direct or consequential damages resulting from the use of, any information, apparatus, method or process disclosed in this publication; or (c) has any liability for damages that result from any negligent act or omission involved in the preparation of the material. Any implied warranty of merchantability or fitness for a particular use is specifically excluded.*

## 4.5 Brick Lintel Flashing

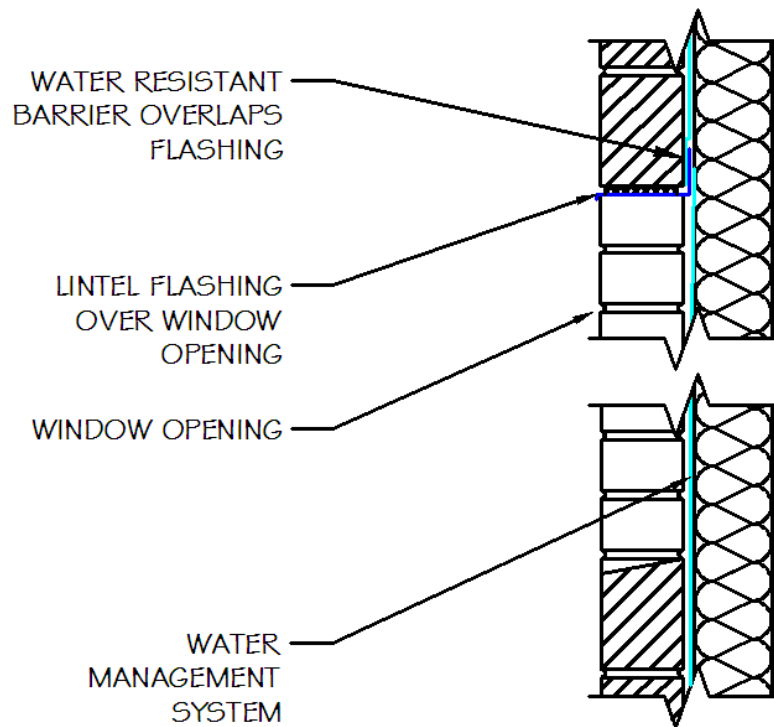

*DISCLAIMER: This material was prepared by North Carolina Energy Efficiency Alliance, a nonprofit organization. Neither the NCEEA, its member organizations, the acknowledged individuals, nor any person acting on behalf of them: (a) makes any warranty, express or implied, with respect to the use of any information, apparatus, method or process disclosed in this publication that such use may not infringe privately owned rights; or (b) assumes any liability with respect to the use of, or for direct or consequential damages resulting from the use of, any information, apparatus, method or process disclosed in this publication; or (c) has any liability for damages that result from any negligent act or omission involved in the preparation of the material. Any implied warranty of merchantability or fitness for a particular use is specifically excluded.*

## 4.6 Brick Veneer Weep-hole Installation and Base Flashing

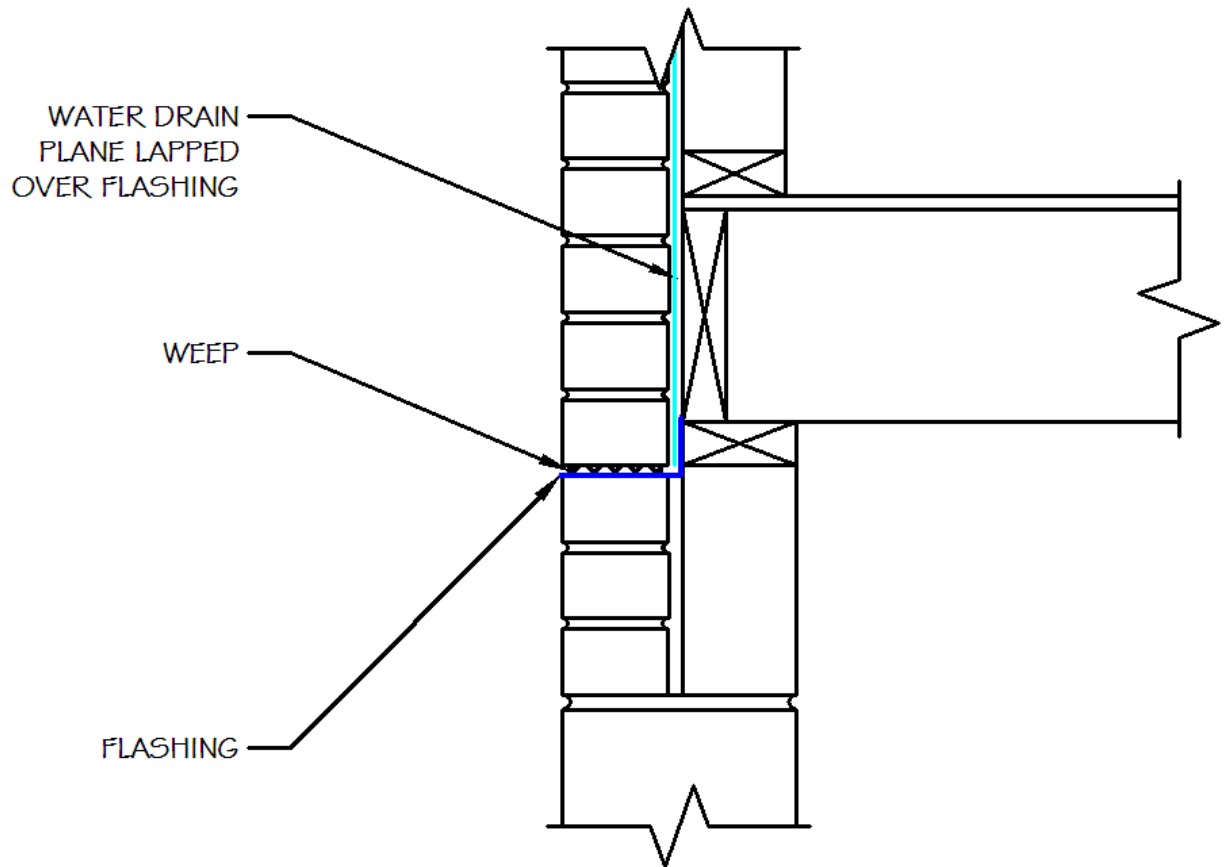

*DISCLAIMER: This material was prepared by North Carolina Energy Efficiency Alliance, a nonprofit organization. Neither the NCEEA, its member organizations, the acknowledged individuals, nor any person acting on behalf of them: (a) makes any warranty, express or implied, with respect to the use of any information, apparatus, method or process disclosed in this publication that such use may not infringe privately owned rights; or (b) assumes any liability with respect to the use of, or for direct or consequential damages resulting from the use of, any information, apparatus, method or process disclosed in this publication; or (c) has any liability for damages that result from any negligent act or omission involved in the preparation of the material. Any implied warranty of merchantability or fitness for a particular use is specifically excluded.*